

Installation Manual



. 0
 . 1 0
 0
 1
 * +
 0
 1 0
 0
 1 0
 / 0
 0 5
 / . * 0 0 / +
 * 0 0 /5222+ 40B
 * +0

* +
 40
 0*
 +
 4
 0 1
 0
 1
 . . * +
 0
 1
 1



/ / 13

/ / 14

/ / 13 / /

/ / 13 /

/ / 14 /

	<p style="text-align: center;">* +</p> <p style="text-align: center;">0</p>	<p style="text-align: center;"><u>0 0</u></p>
--	--	--

* +

402

0

00

0

/

0

01 5

0 0 0

/5222

403

01 50

* +

* +

0
0

0

/

0



032 3

034 03 0

* + 240 5 2

“34 ”0

522 0

* +

34 13 0

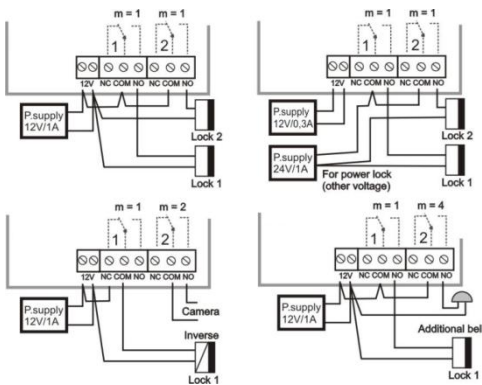

. Either “NO”
Normally Open or “NC”
Normally Closed”

1

0

0



1 1 0
 1 1
 1 1
 0 0 0 * +
 4230 3 . 3.
 3456 0
 1
 32 (default) 33 (default) 0
 0 0423 . 423 . 00 3456 0
 0 . 3456 0 .



30
* _____ +0
+
.
0
0
*



1

1

3 4

0

40

*

+

0

1

0

40 00 . .

40 01 5 0

00 42. /5222. /422 .

42.

400 00

/ . . / 0

40 01 5

0 00 / . . / 0

* +- 0 00

4 . 4 0 0

* + 1

4 * 4 +

0

30 4

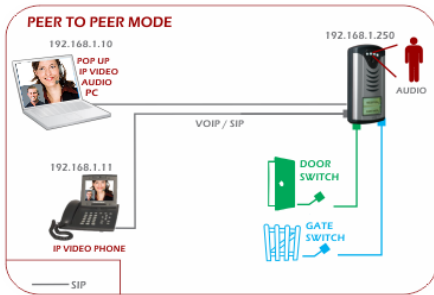

0
1
0
0
4 * +

40

*

+

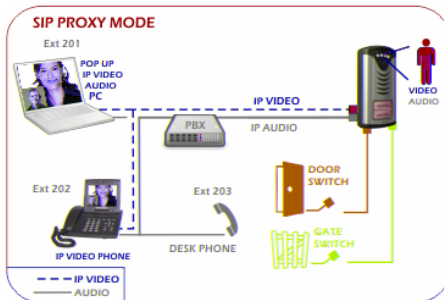

0
0
4
* +

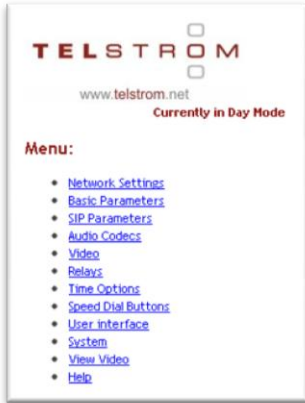

0

3 40 00 2 * +0
113 40 00 2
3456
* +0

Network Settings:

DoorPhone Hostname:

IP set via DHCP:

DHCP client ID:

IP Address:

Network Mask:

Default Gateway:

Primary DNS server:

Secondary DNS server:

0
 “IP set via
 DHCP”

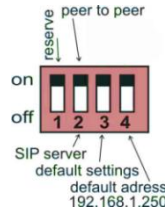

6
 * +0
 5 * +0
 0

Basic Parameters:

1 Time Profile:

Day/Night Mode

Busy Mode

2 Extend duration of current call:

* - star

- hash

3 Terminate call Codes:

Code 1:

Code 2:

4 Code of switching:

Code to switch to Day profile:

Code to switch to Night profile:

5 Day/Night Timer Profile:

Manual switching

Timed switching

6 IP Modular: Keypad Mode:

Direct Dialing

1-64 coded dialing

7 IP Modular: position of keypad:

8 Backlight mode:

Off

Auto

30 _____
 _____ 0

40
 either a “ ” or “ ” to extend
 0

50
 60 0

0
 0 + _____ + _____ 0
 0 * +
 0 + _____ - 00
 0 0 0 + _____ 3/ 60
 0 * +
 0 0 0 1
 0

SIP parameters:

Always send 180 Ringing:	<input checked="" type="radio"/>
Send 183 session in progress:	<input type="radio"/>
Enable Symmetrical RTP:	<input type="checkbox"/>
Send DTMF as SIP INFO:	<input checked="" type="radio"/>
Send DTMF according to RFC2833:	<input type="radio"/>

4 * + _____

SIP parameters:

SIP Proxy Server	Address:	<input type="text"/>
	Port:	<input type="text" value="5060"/>
SIP Registration Server	Address:	<input type="text"/>
	Port:	<input type="text" value="5060"/>
Account	Username:	<input type="text"/>
	Password:	<input type="text"/>
	Expiration [sec]:	<input type="text" value="600"/>

_____ 0

Audio Codecs:

Priority 1:	<input type="text" value="G711µ"/>
Priority 2:	<input type="text" value="G711a"/>
Priority 3:	<input type="text" value="G726-32bit"/>
Priority 4:	<input type="text" value="GSM"/>
<input type="button" value="default values"/> <input type="button" value="save changes"/>	

4 * + 4

0

0

0

0

1

0

“

” or

“

”

0

0

0

Video:

Resolution:	<input type="text" value="320 x 240"/>
Frames per sec.:	<input type="text" value="5"/>
Brightness:	<input type="text" value="37"/>
Contrast:	<input type="text" value="50"/>
Colour:	<input type="text" value="0"/>
Hue:	<input type="text" value="0"/>
Gamma:	<input type="text" value="25"/>

0

Relay 1:

1 Relay mode:	<input type="text" value="1"/>
2 Door Phone Keypad Day/Night Code:	<input type="text"/>
3 Door Phone Keypad Day Code:	<input type="text"/>
4 Door Phone Keypad Night Code:	<input type="text"/>

Relay 2:

1 Relay mode:	<input type="text" value="1"/>
2 Door Phone Keypad Day/Night Code:	<input type="text"/>
3 Door Phone Keypad Day Code:	<input type="text"/>
4 Door Phone Keypad Night Code:	<input type="text"/>

Tenant code:	<input type="text" value="55"/>
Relay duration [sec]:	<input type="text" value="05"/>
Control incoming call:	<input checked="" type="checkbox"/>

Tenant code:	<input type="text" value="66"/>
Relay duration [sec]:	<input type="text" value="05"/>
Control incoming call:	<input checked="" type="checkbox"/>

Tenant code:	<input type="text"/>
Relay duration [sec]:	<input type="text"/>
Control incoming call:	<input type="checkbox"/>

Mode 5, delay between relays 1 and 2 [sec]:

0

1

6

5

0

/ 0

. / 0
 6
 0
 6
 3
 0
 4
 0
 3
 0
 4
 0
 0
 1
 4
 1
 3 (4
 0 0 0
 "121121"
 0 0

Tips: Don't use similar codes for external use. E.g. 12221 & 12222

5 3/4
 3 4
 0
 0
 0
 with "*" 0 0, 3
6 23 -

7

8

23-

Time Options:

Maximum call duration [min]:	<input type="text" value="2"/>
Numbers of rings:	<input type="text" value="1"/>
Inter-digit DTMF delay [sec]:	<input type="text" value="2"/>
Duration between hangup and redial [sec]:	<input type="text" value="2"/>
Duration before redial [sec]:	<input type="text" value="25"/>
Relay activation tones:	<input checked="" type="checkbox"/>
Audio signaling of others tones:	<input checked="" type="checkbox"/>
<input type="button" value="default values"/> <input type="button" value="save changes"/>	

40

			0
			* +
			3 40
			020 2
			3 40
			020
			0

User interface:

Video on start page:	<input checked="" type="checkbox"/>
Video in SIP call (H.263) :	<input checked="" type="checkbox"/>
Web interface TCP port:	<input type="text" value="80"/>
Enable telnet:	<input type="checkbox"/>

0

0

the IT administrator's requirem

0

System:

SIP Firmware version: 1.48 Base Firmware version: 6.0	
Download log file	<input type="button" value="start enhanced logging"/>
Show call logs	
Show SIP logs	
Network Time Server (NTP) Used for getting the current date/time:	
<input type="text"/>	GMT-13 <input type="button" value="save"/>
Syslog server:	
<input type="text"/>	<input type="button" value="save"/>
Firmware upgrade:	
<input type="text"/>	<input type="button" value="browse"/> <input type="button" value="save"/>
Upload language:	
<input type="text"/>	<input type="button" value="browse"/> <input type="button" value="save"/>
Save configuration:	
<input type="button" value="save"/>	
Upload configuration:	
<input type="text"/>	<input type="button" value="browse"/> <input type="button" value="save"/>

0 0

0

0

/

0

0
1
.
0
0
.
0
0
0

1



The default levels in most cases should be sufficient, if you do adjust make a note of the factory setting. .

0

0

	32	. 322
	522	- 5622
.	34	4 . 32/34 4
0	522	34
0	6	3
0	4	52
	/42	- 2

